

User manual

BGK1000

Manufactured by



HINZ Messtechnik GmbH
Alpenrosenweg 13
45770 Marl, Germany

www.hinz-mt.de

Distributed by



Geotomographie GmbH
Am Tonnenberg 18
56567 Neuwied, Germany

www.geotomographie.de

The latest version of this manual is available at www.hinz-mt.de

Table of contents

What's new in this manual	4
0. Important safety notices and warnings	4
Sonde	4
Winch	4
1. System overview	5
1.1 The BGK1000 Sonde.....	6
1.2 The BGK1000 Trigger Unit.....	7
2. Detailed technical description	8
2.1 BGK1000 Sonde.....	8
2.1.1 The clamping mechanism	8
2.1.2 The clamping force.....	8
2.1.3 The optimal opening angle	9
2.1.4 The length of the clamping arm.....	10
2.1.5 The stiffness of the clamping arm.....	10
2.2 BGK1000 Trigger Unit.....	12
2.2.1 Power supply.....	12
2.2.2 Connection to the logging cable on the winch	12
2.2.3 RS-485 data rates on logging cable.....	12
2.2.4 USB connection	12
2.2.5 Trigger inputs	13
2.2.6 Depth counter	13
2.2.7 Reference channels input	13
2.3 Connections winch to Sonde	14
2.3.1 Logging cable integrity	14
2.3.2 Cable head connections	14
2.3.3 Identifying connections.....	15
2.3.4 Identification procedure	15
3. Electronics and firmware	16
3.1 Sonde and Trigger Unit electronics.....	16
3.2 DSP Firmware in Trigger Unit and Sonde.....	17

4.	Acquisition software	17
5.	Conducting a measurement.....	18
5.1	Preparation	18
5.2	Repeat at different depths.....	18
5.3	Post measurement procedures.....	18
6.	Interpreting the results	19
7.	Maintenance	21
7.1	Cleaning and lubrication	21
7.2	Service interval.....	21
8.	Clamping examples	22
8.1	Maximum opening angle	22
8.2	Optimal opening angle.....	22
8.3	Strong clamping force with standard bronze arm	23
8.4	Dangerous opening angle with standard steel arm	23
8.5	Moderate clamping force with standard steel arm	24
8.6	Strong clamping force with standard steel arm.....	24
8.7	Strong clamping force with short bronze arm	25
8.8	Strong clamping force with short steel arm	25
8.9	Strong clamping force with elongated arm	26
9.	Technical appendix	27
9.1	Trigger Unit connectors	27
9.1.1	12V (power input).....	27
9.1.2	WINCH.....	27
9.1.3	DEPTH.....	28
9.1.4	TRIGGER	29
9.1.5	GEOPHONE.....	31

What's new in this manual

This revision 2 of the User Manual BGK1000 documents new features, corrections of typographic errors and reported document errata.

Changes from revision 1 (March 2015) include:

- 1.1 Hydrophone version
- 2.1.2 Corrected timing of clamping mechanism
- 2.1.3 Optimal opening angle
- 2.2.7 Input impedance of reference channel
- 8 Clamping examples
- 9.1.4 Schematic of trigger input

0. Important safety notices and warnings

Sonde

Connect the cable head to the BGK1000 Sonde only if the BGK1000 Trigger Unit is completely disconnected from power.

The voltage inside the cable head can cause shocks or severe injury or death, especially in wet areas.

Care should be taken when operating the strong clamping arm, be aware of trapping fingers.

Winch

Under bad geological conditions or in case of an electrical fault it might be possible that the clamping arm is firmly pressed against the borehole wall and is blocked in the borehole. In this case the Sonde has to be pulled out of the borehole with high force.

Make sure that the winch is secured before applying a heavy load on the logging cable. It is strongly not recommended to use lightweight or not properly mounted winches.

1. System overview

BGK1000 is a digital data acquisition system for borehole seismic surveys. It consists of the BGK1000 Sonde, the BGK1000 Trigger Unit and Acquisition software on a Windows PC.

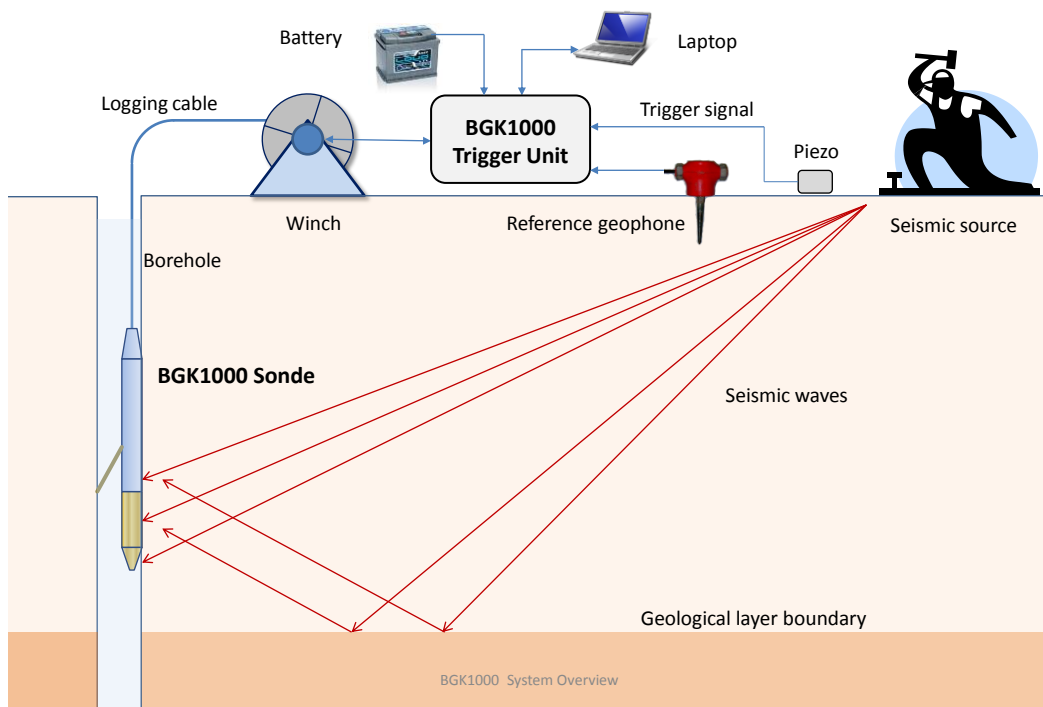

Fig. 1 BGK1000 system overview

The BGK1000 Sonde is the heart of the acquisition system. It features a rich set of sensors i. g. 3 geophones, hydrophone, compass, connected to powerful electronic boards incl. 24-bit AD-converter and DSP. Due to a strong clamping arm it ensures high quality results even in critical boreholes. It operates on standard 4-conductor logging cable up to 2,000 m depth and in borehole diameters up to 250 mm (10 ").

The BGK1000 Trigger Unit is the RS-485 bus master and communicates with the Sonde over two wires of the logging cable. It also supplies the sonde with 72 V DC. The Trigger Unit is controlled from a PC via USB and needs a 12 V 3 A DC power supply. A trigger event synchronizes data acquisition in the Sonde. A reference geophone at the surface allows precise timing analyses.

A laptop with acquisition software controls the data survey, communicates with the trigger unit via USB and stores the seismic data records in SEG-2 files.

The surface equipment is usually a winch with logging cable and a seismic source (drop-weight or vibrator). The seismic source produces seismic waves in the underground and emits a trigger signal from a piezo or a hammer switch.

1.1 The BGK1000 Sonde

The BGK1000 Sonde is a digital 3-component borehole geophone with an electro-mechanical clamping arm.

The BGK1000-H is the 4-component version and has in addition a hydrophone at the Sonde tip.

Sonde body mechanics

Stainless steel, length 80 cm (85 cm BGK1000-H), diameter 60 mm, pressure 200 bar, weight 8 kg (8.5 kg BGK1000-H)



Top sub

- 1" Gearhart-Owen 4-pin cable head

Power electronics and motor

- central power supply
- RS-485 communication line drivers
- electric motor and motor electronics

Clamping module

- clamping arm
- motor controlled clamping force

Geophones and electronics

- three geophones orthogonally mounted
- four channel 24 bit ADC
- DSP Blackfin 548
- compass

Hydrophone

(only in BGK1000-H)

- HQ2000 casted in PU

Fig. 2 BGK1000-H Sonde

1.2 The BGK1000 Trigger Unit

The Trigger Unit supplies the Sonde with DC voltage and communicates with the Sonde via the logging cable. The electronics and firmware incl. DSP and 24-bit ADC of the Trigger Unit and the Sonde are perfectly matched.



Fig. 3 BGK1000 Trigger Unit

Connectors and controls		
12 V	female connector 2 contacts	power input
WINCH	female connector 5 contacts	Sonde supply, communication
DEPTH	female connector 4 contacts	rotary encoder
POWER	closing switch	12 V on/off
ACT	LED blue	activity (1 sec flash)
12 V	LED green	12 V power on
SONDE	closing switch	72 V on/off to Sonde
RS-485	LED white	RS-485 traffic
72 V	LED green	72 V Sonde on
TRIGGER	female connector 7 contacts	input
TRIGGER	LED green	trigger event
TRIGGER	push button (red)	manual trigger
GEOPHONE	female connector 3 contacts	reference signal input
USB	USB – B	connection to PC
Housing	Cast aluminum 260 x 160 x 90 mm, weight 3 kg	

2. Detailed technical description

2.1 BGK1000 Sonde

2.1.1 The clamping mechanism

The clamping mechanism (Fig. 4) consists of the clamping module body (1), a rotating worm shaft (2), and a worm gear (3). The fitting screw (4) fixes the worm gear to the clamping module body.

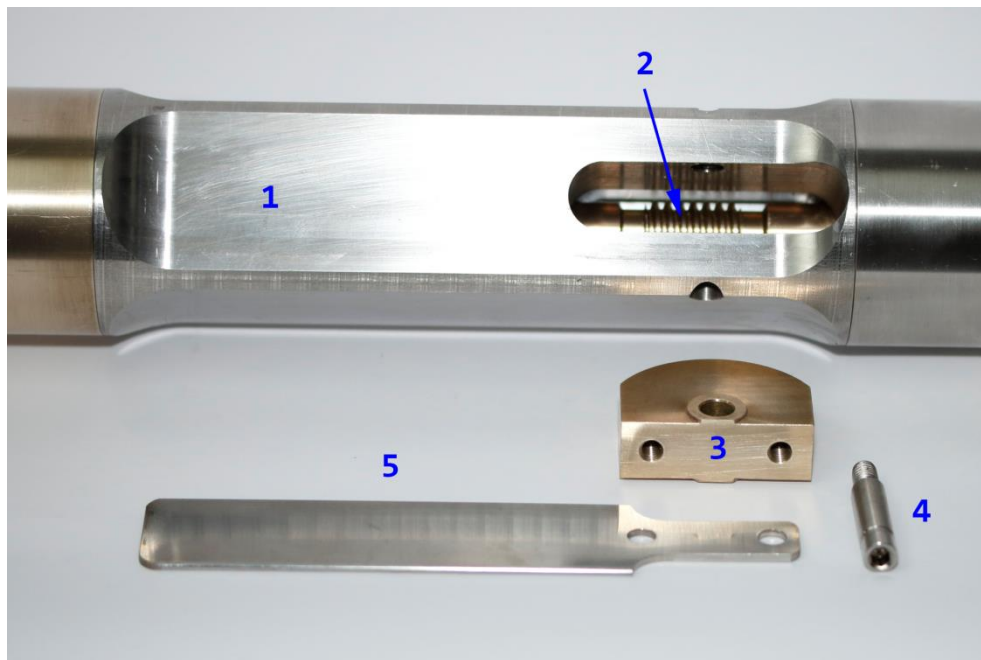

Fig. 4 The clamping mechanism

The clamping arm (5) is fastened at the worm gear with 6 mm metric screws. The spacing of the threaded 6 mm holes in the worm gear is 30 mm.

2.1.2 The clamping force

To obtain a high-quality record free of cable waves and of resonant vibration in the seismic frequency band, the Sonde must be clamped with a force several times of its own weight.

When the BGK1000 Sonde arm clamps against the borehole wall, the motor will stop automatically, when the motor current exceeds a preset value, default 0.4 A. This value represents a clamping force of approx. 180 N, which is nearly twice of the Sonde weight (force to weight ratio is 2:1). The exact clamping force varies with arm length and opening angle.

If it is necessary to increase the clamping force, the preset of the motor current can be increased up to 1.0 A.

With a short arm and an opening angle of 45° a clamping force of 500 to 600 N can be reached, which is a force to weight ratio of 6 to 7.

See more information about clamping in chapter 8.

The clamping quality is determined by a reliable contact between the Sonde and the borehole wall. Good clamping quality must be evaluated by experiment. High frequency surveys generally require a stronger clamping force.



Fig. 5 Sonde with standard steel clamping arm

2.1.3 The optimal opening angle

The optimal opening angle is between 10° and 50°. If the opening angle rises above 60°, the user should switch off the motor and mount a longer clamping arm. Running over 70°, the worm gear runs free and the motor switches off automatically after 50 seconds. In this case a complete closing of the arm is required to get back to the 0° position. A complete opening of the arm from 0° to 60° angle takes 30 seconds.

2.1.4 The length of the clamping arm

The standard arm length is 150 mm (Fig. 6 No. 6) and covers borehole diameters from 75 mm (3") to 140 mm (5.5").

The 105 mm short arm (Fig. 6 No. 1 to 3) can be used up to 110 mm (4.3").

If the borehole diameter is larger than the standard arm reaches, a combination of arms (Fig. 7) can widen the range up to 250 mm (10").

2.1.5 The stiffness of the clamping arm

The stiffness of the clamping arm should be adapted to the borehole conditions. The standard arm 150 x 30 x 2 mm is made of stainless spring band steel (Fig. 6 No. 6) and is usable in a wide range of boreholes. In unstable boreholes tendentiously longer and weaker steel arms are recommended. A weaker arm version is 150 x 20 x 2 mm (Fig. 6 No. 5).

Stiffer arms are preferable used in hard rock boreholes or when higher clamping force is necessary. Stiffer arms are made of phosphorous bronze, such as 150 x 20 x 5 mm or 105 x 20 x 5 mm (Fig. 6 No. 1, 4). Sharp edges can improve clamping quality under certain circumstances.

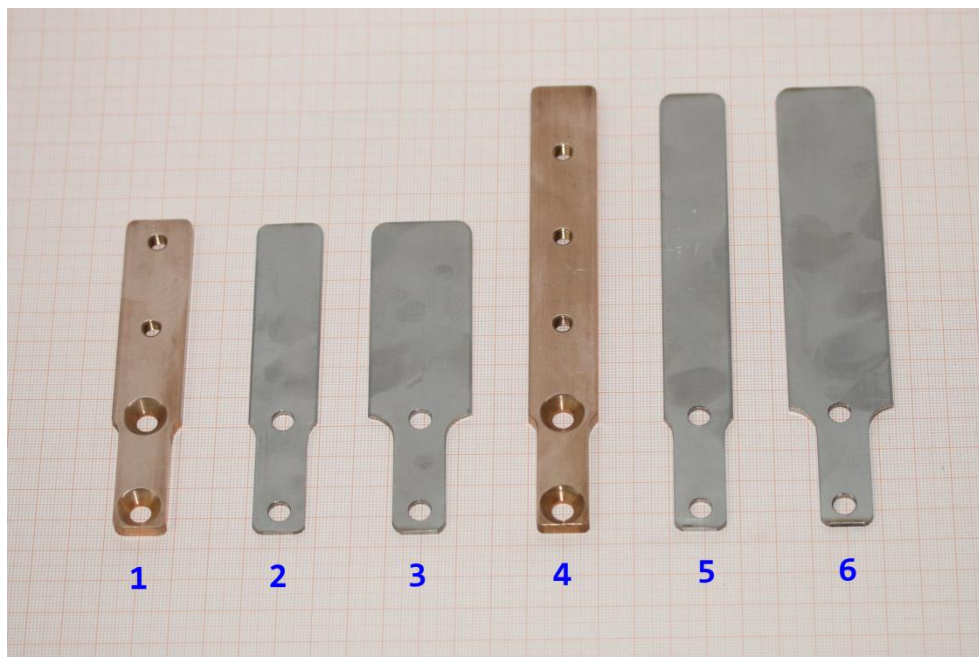

Fig. 6 A collection of clamping arms

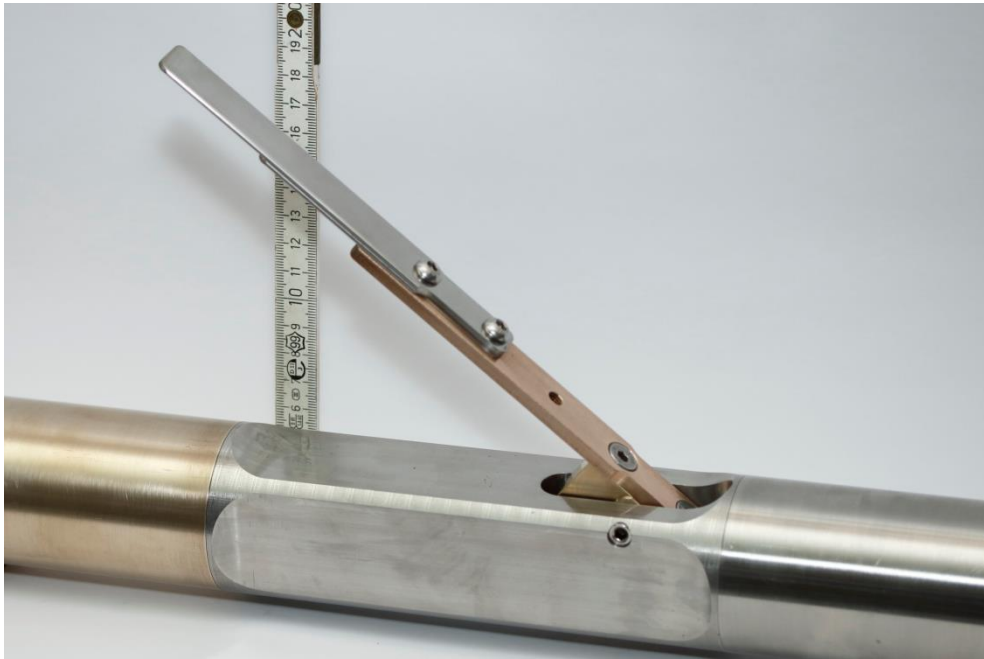

Fig. 7 Extended clamping arm for 200 mm boreholes

2.2 BGK1000 Trigger Unit

2.2.1 Power supply

The Trigger Unit runs from a 12 V DC supply, typically a car battery or a power line voltage converter. The Trigger Unit draws a current of approx. 0.5 A. The current may rise shortly over 2 A while the Sonde is clamping.

2.2.2 Connection to the logging cable on the winch

The Trigger Unit supplies DC voltage to the Sonde, normally +72 V. This voltage is connected over two wires of the logging cable (line 2 and line 4 in parallel). Line 1 and line 3 of the logging cable carries the RS-485 half duplex communication bus. RS-485 driving voltage level is 3.3 V.

Logging cable	Type	Voltages
Line 1	Signal	RS-485 A (+2.0 V DC)
Line 2	Power	72 V DC
Line 3	Signal	RS-485 B (+1.8 V DC)
Line 4	Power	72 V DC
Armor	GND	power return

2.2.3 RS-485 data rates on logging cable

The initial RS-485 data rate of the Sonde is 38.4 kbps.

The RS-485 serial data rate depends on length of the logging cable and is selectable up to 256 kbps.

Prior to a measurement the RS-485 data rate of the Sonde should be increased in the acquisition software to reduce data transmission times. RS-485 data rate must be lower than the Virtual Com Port on the USB.

The following RS-485 data rates are typical between Sonde and Trigger Unit:

Depth	Rate in kbps
2,200 m	96
2,000 m	168
800 m	256 and more

2.2.4 USB connection

The Trigger Unit is connected to a PC or laptop via USB and controlled by the acquisition software. The Virtual Com Port driver allows data rates up to 921 kbps.

A standard setting that works in many cases is 115.2 kbps on USB and 103.2 kbps on RS-485 bus.

2.2.5 Trigger inputs

The BGK1000 Trigger Unit receives a trigger signal from the seismic source (hammer or vibrator). On a trigger event a precisely timed command is sent from the Trigger Unit via RS-485 bus to the BGK1000 Sonde and both units start synchronized data acquisition.

The trigger input circuitry is driven from an extra isolated 5 V power supply to avoid cross feed and power ground effects.

There are three different trigger inputs.

- Piezo high impedance input
- TTL (5 V) falling edge (Time Break)
- TTL (5 V) rising edge

All inputs work in parallel and produce a short pulse to the DSP electronics. The pulse can be observed by the trigger LED. See the trigger inputs circuitry in the technical appendix 9.1.4.

2.2.6 Depth counter

A depth counting unit in the Trigger Unit allows connection to a rotary depth encoder. This input circuitry is also driven from the extra isolated 5 V power supply. The maximum load for an external rotary encoder is 0.2 A. Open collector types work well because of build in 2.2 k Ω pull-up resistors.

2.2.7 Reference channels input

The Trigger Unit has four 24-Bit ADC channels for reference geophone acquisition at the surface. The inputs are isolated with high quality audio transformers. Signal level at ADC input is nominal 500 mVpp. Due to input protector resistors and transformation ratio the real input sensitivity is 600 mVpp (at 50 Ω). The input impedance of the transformer is 1.2 k Ω .

If one of the geophone inputs should record the sweep reference output of a vibrator, the signal level has to be attenuated, see a typical attenuator circuitry in the technical appendix 9.1.5.

2.3 Connections winch to Sonde

2.3.1 Logging cable integrity

The standard 3/16" (4.8 mm) 4-conductor cable 4H18 has a wire resistance of 80 Ω per km. The steel armor resistance is 22 Ω per km.

Leakage resistance between armor and wires must be higher than 2 M Ω .

If there is any problem with tool operation or communications, the logging cable should be tested for electrical integrity with an ohmmeter.

2.3.2 Cable head connections

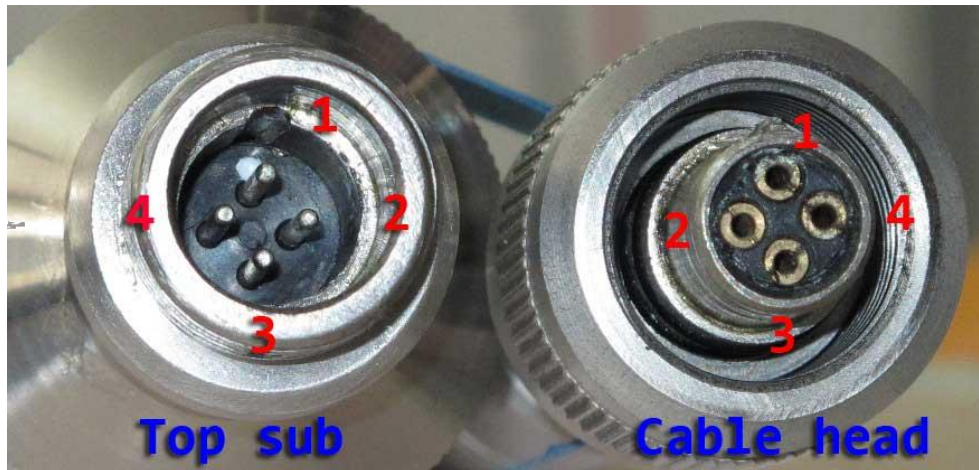

Fig. 8 Gearhard Owen 4-pin cable head connectors

The Sonde is connected to the logging cable as follows:

Logging cable	Type	Voltages
Line 1	Signal	RS-485 A (+2.0 V DC)
Line 2	Power	72 V DC
Line 3	Signal	RS-485 B (+1.8 V DC)
Line 4	Power	72 V DC
Armor	GND	power return

2.3.3 Identifying connections

On an unknown winch, resistance measurements with an ohmmeter can identify the correct electrical assignment.

2.3.4 Identification procedure

Connect the cable head to the BGK1000 Sonde and make resistance measurements at the winch connector.

Example:

On a 450 m logging cable following resistances can be measured:

No.	Measurement between	Resistance	Results
1	Armor – Line 1	530 Ω	RS-485 bus seems ok, value is higher than 3 polarity of RS-485 bus is ok
2	Armor – Line 2	2 M Ω	leakage resistance of 2 M Ω is tolerable, (minimum is 1 M Ω) 72 V DC power connection is ok
3	Armor – Line 3	470 Ω	RS-485 bus seems ok value is lower than 1 polarity of RS-485 bus is ok
4	Armor – Line 4	2 M Ω	See measurement 2
5	Line 2 – Line 4	74 Ω	Line 2 and line 4 are shorted in the Sonde, so you can determine the real line resistance, which is $74 \Omega / 2 = 37 \Omega$, $37 / 80 = 0.46$ (km) the length of 450 m seems ok

Warning

If there are big discrepancies in resistance values, no measurement shall be performed. Never determine the correct connection by means of trial and error. The 72 V may destroy the RS-485 line drivers.

3. Electronics and firmware

3.1 Sonde and Trigger Unit electronics

The electronic of the Sonde and the Trigger Unit are based on the same hardware architecture to allow perfectly matched operations.

Features	Sonde	Trigger Unit
Power supply	36-72 V DC at cable head, 60 mA stand-by	11-18 V DC input, 0.5 A stand-by, 2 A max.
PC connection		USB virtual serial port up to 921.600 kbps
Preamplifier	Fixed gain 50, 50 mV is full range	Fixed gain 10, 500 mV is full range
Motor	12 V, 20 W, selectable clamping force	
Communication	Half duplex 2-wire RS-485 up to 256 kbps	
A/D Converter	4-channel 24 bit delta sigma	
Sampling rate	48.000 sps fixed	
Downsampling	16.000 sps ...to... 250 sps in firmware	
Trace length	21 s max at 48.000 sps	
DSP	Blackfin 548	

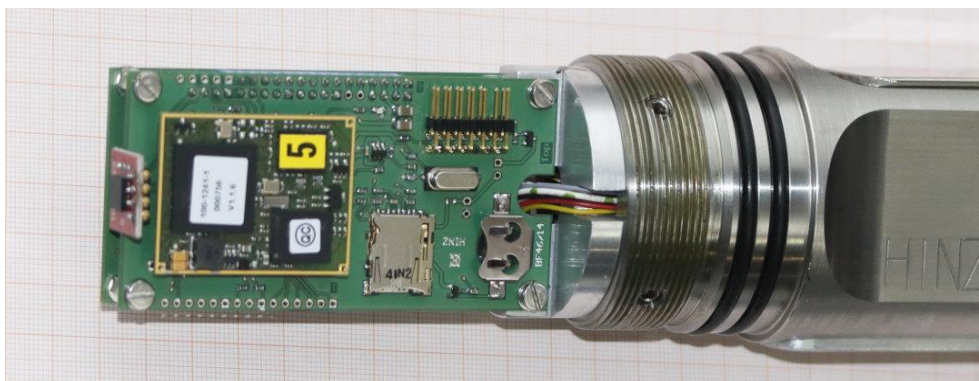

Fig. 9 Sonde DSP-Board

3.2 DSP Firmware in Trigger Unit and Sonde

The DSP firmware of the Trigger Unit and the Sonde has a perfectly matched command set. Following functions give a short overview. The firmware is upgradable.

Functions	Remarks
Command protocol	prepared for multilevel surveys
Logical addresses	1 to 10 = Trigger Units, 11 to 250 = Sonde Units
Enable	sets sampling rate and recording time
Ring buffer	4 channels, 21 s at 48 ksps
Trigger	large pre- and post-trigger values
Read data	Data formats i8, i32, f32
Communication	Speed tests from 38 kbps to 256 kbps
Clamping force	Set and read motor current 0.4 to 1.0 A
Clamping arm	Read opening angle 0 to 70°
Compass	Read magnetic north, calibration
Depth counter	Read depth, inch or metric, free wheel diameter

4. Acquisition software

The acquisition software provides the user interface for the BGK1000 Sonde and BGK1000 Trigger Unit. It works with a command protocol to the trigger unit via USB (Virtual Serial Port). It sets recording parameters, sample rate, trace length, pre-trigger and data format. It reads geophone data, compass and depth counter. It displays seismic traces and stores seismic data to SEG-2 files. It runs on Windows 7 and up.

For installation and start refer to the BGK1000 acquisition software manual.

5. Conducting a measurement

To start a seismic measurement the BGK1000 Sonde and Trigger Unit have to be connected to the surface equipment in following sequence:

5.1 Preparation

1. Test logging cable integrity and correct connections
2. Connect the BGK1000 Sonde to the cable head
3. Wire up the Trigger Unit to the winch, laptop, trigger, etc.
4. Start the acquisition software on laptop
5. Power up and switch on the Trigger Unit
6. Switch power to the Sonde
7. Set RS-485 communication speed on logging cable
8. Test the clamping functions
9. Lubricate clamping module
10. Mount and test the proper length of the clamping arm
11. Calibrate the Sonde compass
12. Lower the Sonde to the start depth location

5.2 Repeat at different depths

13. Open the clamping arm and press the Sonde against the borehole wall
14. Take weight off the logging cable to suppress cable waves
15. Enable data recording of Sonde and Trigger Unit
16. Fire the seismic source
17. Read seismic traces from the Sonde and the uphole reference
18. Write traces to a SEG2 file
19. Repeat and stack measurements if necessary
20. Release the clamping arm and watch that the logging cable gets back to tension
21. Pull the Sonde to a different depth location

5.3 Post measurement procedures

22. Clean Sonde with a powerful water jet
23. Disassemble and clean the clamping arm drive mechanism
24. Lubricate worm and gear

6. Interpreting the results

The interpretation of results requires in-depth knowledge of seismic geophysics. The following two screenshots show typical outputs of seismic software from BGK1000 measurements.

Example 1:

Data examples from a shear wave vibro survey in a 100 m borehole.

Sample rate 1 ms, sweep length 10 s, 20 to 150 Hz

Three correlated traces are X, Y, and Z-Component.

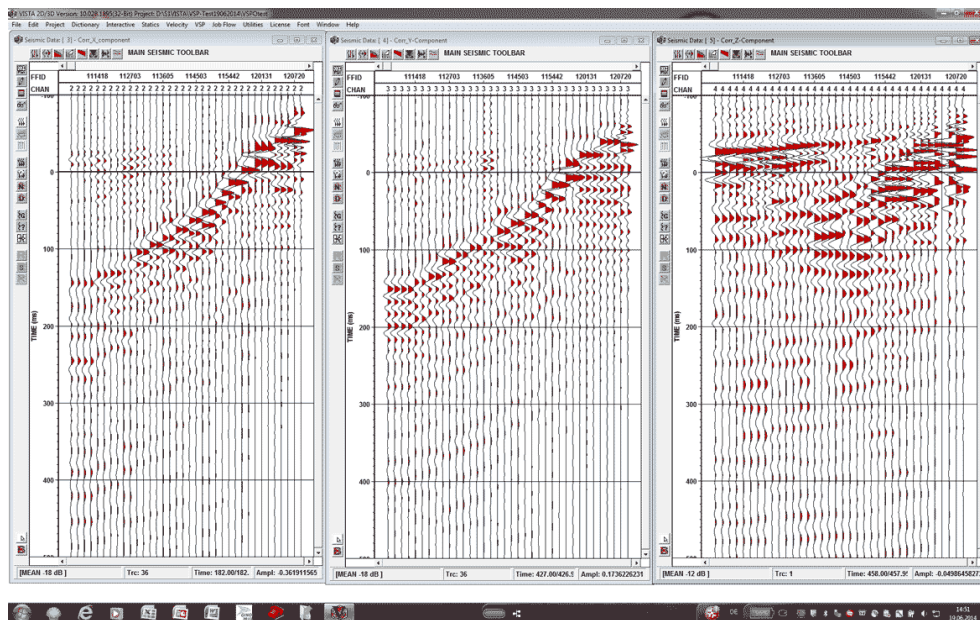

Fig. 10 Shear wave vibro survey

Example 2:

Data example from correlated shear wave sweeps under severe powerline noise surrounding.

The BGK1000 shows excellent noise reduction, complete absence of powerline noise 50 Hz, 150 Hz, 16.66 Hz.

Depth 720 m, sample rate 1 ms, sweep length 20 s.

Left trace P-Wave, right trace S-Wave.

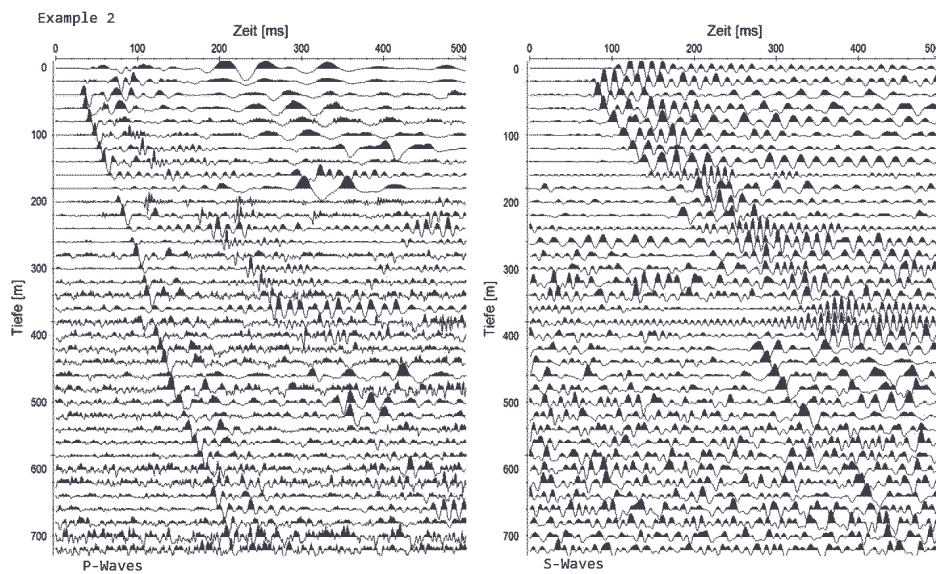

Fig. 11 Shear wave vibro survey under severe powerline noise

7. Maintenance

7.1 Cleaning and lubrication

Keep the cable head threads and O-Ring free of grit and dirt. Lightly lubricate threads with white grease or similar and the O-Rings with silicone grease. Protect electronic connections with caps.

After measurement the mechanical clamping components should be disassembled and cleaned with a powerful water jet. All components are corrosion-resistant. Lubricate the worm shaft and gear always after cleaning.

When operating in corrosive or saline environments change all damaged O-Rings immediately after the measurement.

7.2 Service interval

Replace the rotating sealing of the worm gear shaft after 1000 clamping actions or at latest after one year of intensive use. Please contact your distributor for spare parts or replacing service.

8. Clamping examples

The following clamping examples serve as guidance for setting the right clamping force and choosing the right clamping arm. Some examples demonstrate the limits of the clamping mechanism.

Clamping force is controlled by the motor shut-off current. No-load current is below 0.2 A. Variations of the shut-off current is set by the Acquisition software. Default value is 0.4 A, if necessary a higher value up to 1.0 A can be set.

8.1 Maximum opening angle

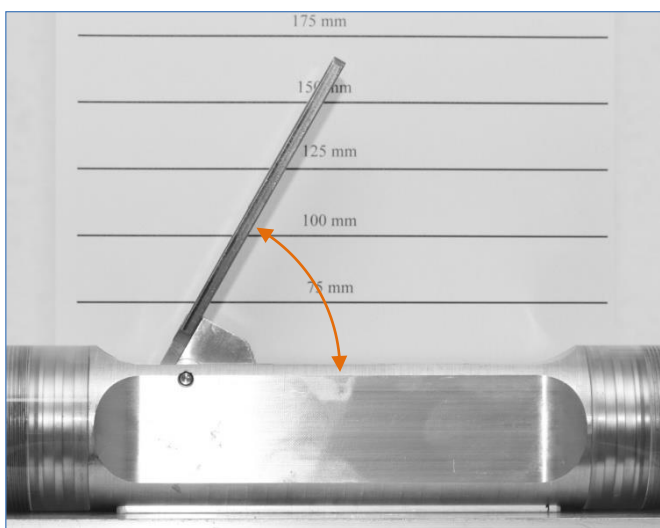

Standard bronze arm:
150 x 20 x 5 mm

Opening angle: 60°
Opening time: 30 s

Use this standard bronze arm in hard rock boreholes below 150 mm diameter

➤ **Keep the opening angle below 60°**

8.2 Optimal opening angle

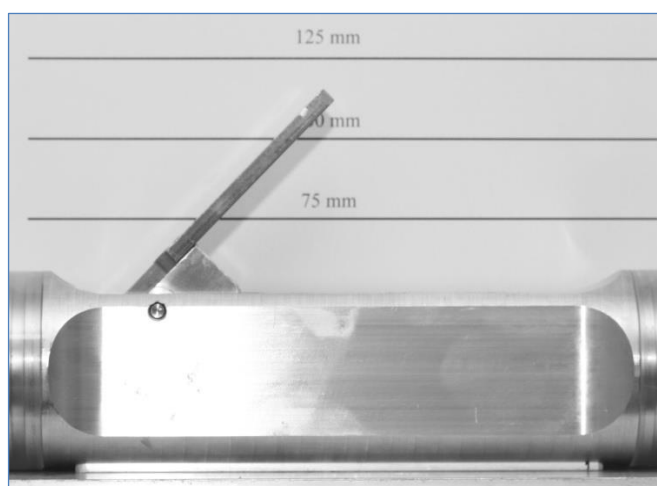

Short bronze arm:
105 x 20 x 5 mm

Opening angle: 45°
Opening time: 22 s

Use this short bronze arm in hard rock boreholes below 110 mm diameter

➤ **The clamping force increases with large opening angles.**

➤ **A good opening angle is in the range of 10° to 50°**

8.3 Strong clamping force with standard bronze arm

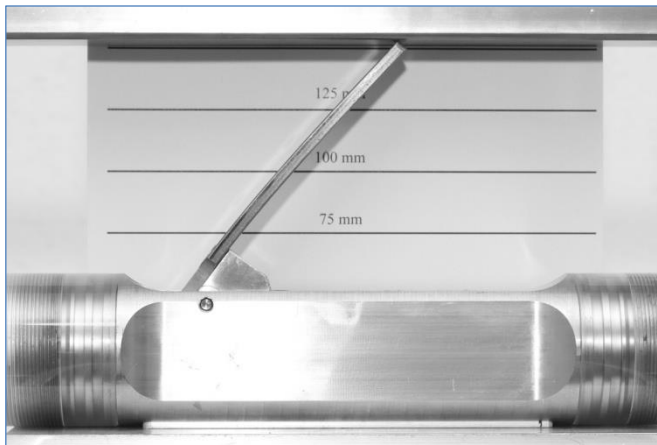

Borehole diameter:
150 mm = 6"

Bronze arm:
150 x 20 x 5 mm

➤ **This is a very strong clamping force. Use with care in good borehole conditions only.**

Opening angle	54°	Angle is large
Motor current	1.0 A	A high value
Press-on force	440 N	Very strong clamping
Force to weight ratio	5 : 1	Arm is slightly bended

8.4 Dangerous opening angle with standard steel arm

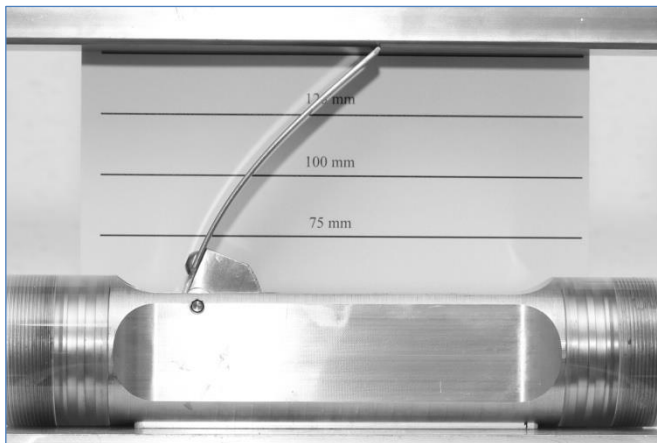

Borehole diameter:
150 mm = 6"

Steel arm:
150 x 30 x 2 mm

➤ **The opening angle is too large. Danger of blocking in the borehole!**

Opening angle	70°	Angle is too large
Motor current	1.0 A	A high value
Press-on force	340 N	Very strong clamping
Force to weight ratio	4 : 1	Arm is distinctly bended

8.5 Moderate clamping force with standard steel arm

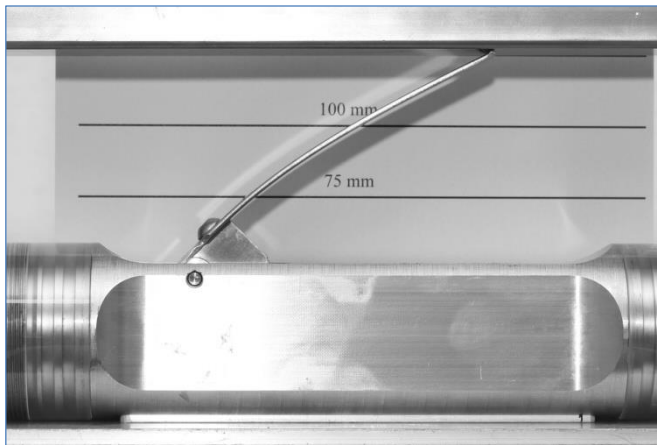

Borehole diameter:
125 mm = 5"

Steel arm:
150 x 30 x 2 mm

➤ **This is a good clamping example.**

Opening angle	44°	Ideal angle
Motor current	0.5 A	Moderate current
Press-on force	160 N	Works well in most borehole conditions
Force to weight ratio	2 : 1	Arm is slightly bended

8.6 Strong clamping force with standard steel arm

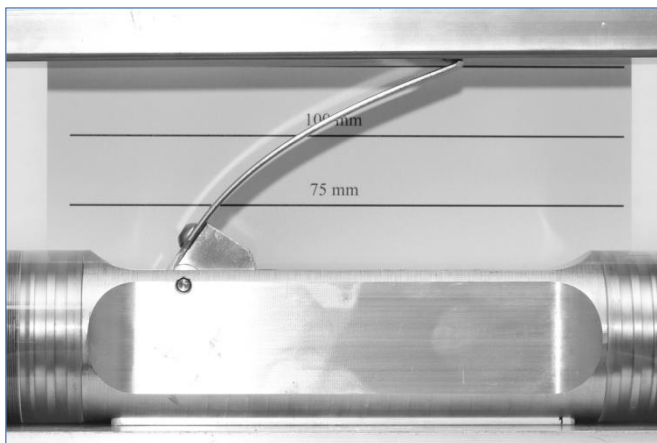

Borehole diameter:
125 mm = 5"

Steel arm:
150 x 30 x 2 mm

➤ **Use this strong clamping force in hard rock boreholes only.**

Opening angle	58°	Angle is near to maximum
Motor current	1.0 A	A high value
Press-on force	300 N	Strong clamping
Force to weight ratio	3.5 : 1	Arm is distinctly bended

8.7 Strong clamping force with short bronze arm

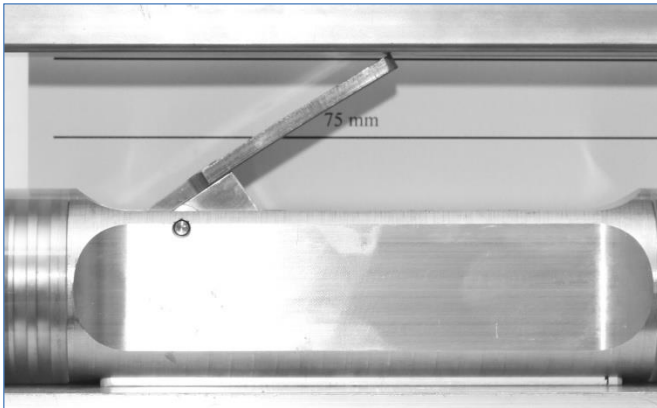

Borehole diameter:
100 mm = 4"

Bronze arm:
105 x 20 x 5 mm

➤ Use the short bronze arm in hard rock or plastic lined boreholes only.

Opening angle	35°	Sharp edge may cut into borehole wall
Motor current	0.5 A	Moderate current with short arm
Press-on force	310 N	Strong clamping
Force to weight ratio	3.6 : 1	Arm is not bended

8.8 Strong clamping force with short steel arm

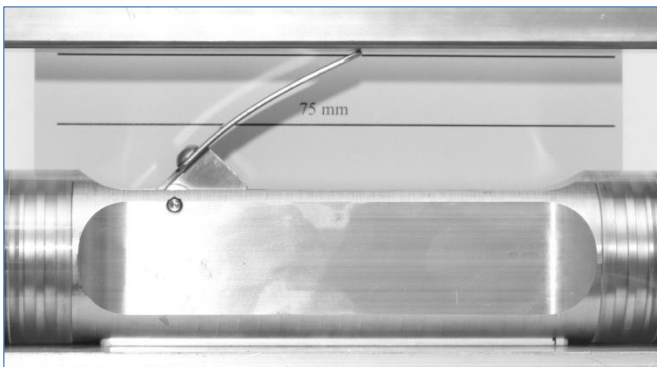

Borehole diameter:
100 mm = 4"

Steel arm:
105 x 30 x 2 mm

➤ The short steel arm should be used in boreholes below 100 mm diameter.

Opening angle	49°	Sharp edge may cut into borehole wall
Motor current	1.0 A	High current with short arm
Press-on force	540 N	Very strong clamping
Force to weight ratio	6 : 1	Arm is distinctly bended

8.9 Strong clamping force with elongated arm

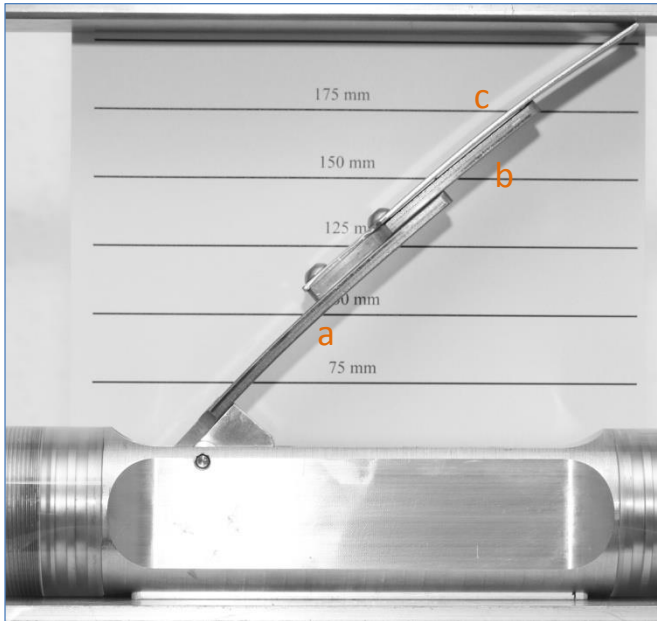

Borehole diameter:
200 mm = 8"

a. Bronze arm
150 x 20 x 5 mm

b. Bronze arm
105 x 20 x 5 mm

c. Steel arm
150 x 30 x 2 mm

➤ Take care in larger boreholes. Do not exceed the maximum opening angle!

Opening angle	50°	Nearly optimal
Motor current	1.0 A	High current
Press-on force	210 N	Strong clamping
Force to weight ratio	2.5 : 1	Arm is slightly bended

9. Technical appendix

9.1 Trigger Unit connectors

All circular connectors with threaded joint M16 x 0.75

Binder series 680 or Lumberg SV or Amphenol C091D.

Acc. to IEC 61076-2-106.

9.1.1 12V (power input)

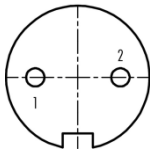

Female connector 2 contacts

Contact	Input	Remarks
Pin 1	+12 V DC	11 to 18 V, 3 A min.
Pin 2	GND	

9.1.2 WINCH

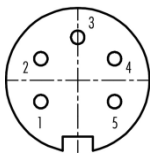

Female connector 5 contacts

Contact	WINCH	Logging cable
Pin 1	RS-485-A	Line 1
Pin 2	+72 V	Line 2
Pin 3	RS-485-B	Line 3
Pin 4	+72 V	Line 4
Pin 5	GND	Armor

9.1.3 DEPTH

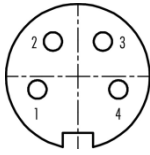

Female connector 4 contacts

Contact	DEPTH	Rotary encoder
Pin 1	EXT_GND	Isolated GND
Pin 2	A+	Internal pull up 2.2 kΩ to EXT 5 V
Pin 3	B+	Internal pull up 2.2 kΩ to EXT 5 V
Pin 4	EXT +5 V output	Isolated, load max. 0.2 A

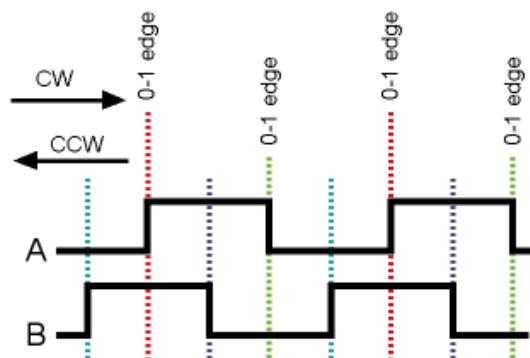

Incremental encoder quadrature phasing

The two output wave forms of a rotary encoder are 90 degrees out of phase. These signals are decoded to produce a count-up pulse or a count-down pulse on each transition.

9.1.4 TRIGGER

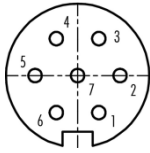

Female connector 7 contacts

Contact	TRIGGER	Remarks
Pin 1	EXT +5 V output	Isolated, external load max. 0.2 A
Pin 2	EXT_GND	Isolated GND
Pin 3	Piezo	High impedance input
Pin 4	TTL falling edge	Time Break input
Pin 5	TTL rising edge	
Pin 6	EXT_GND	Isolated GND
Pin 7	not connected	

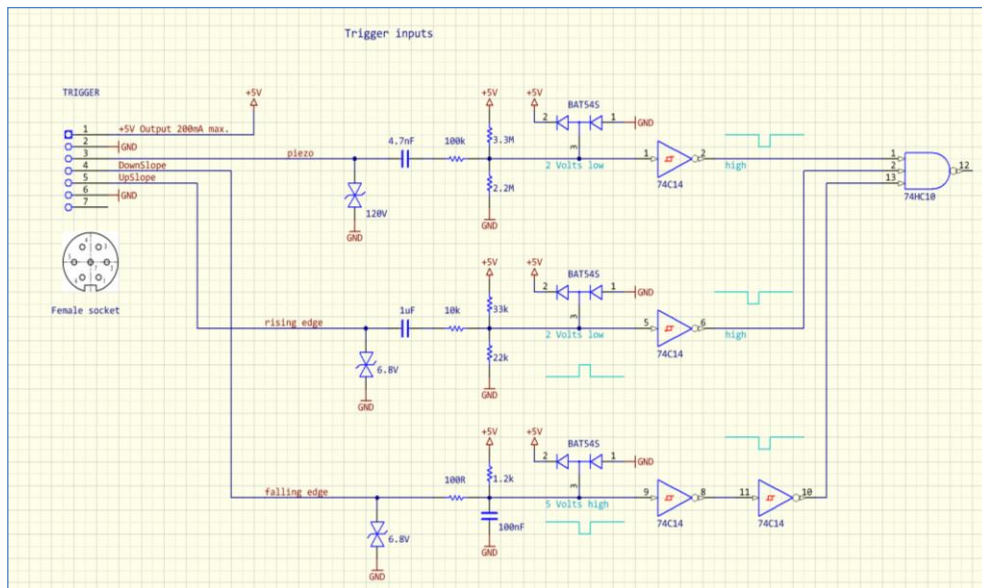

Trigger inputs schematic

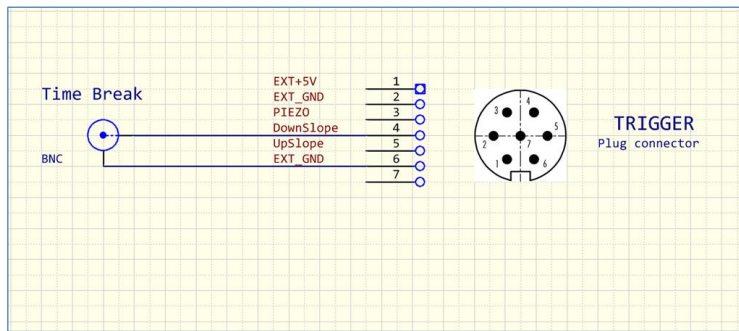

Example connection to Vibrator Time Break Output

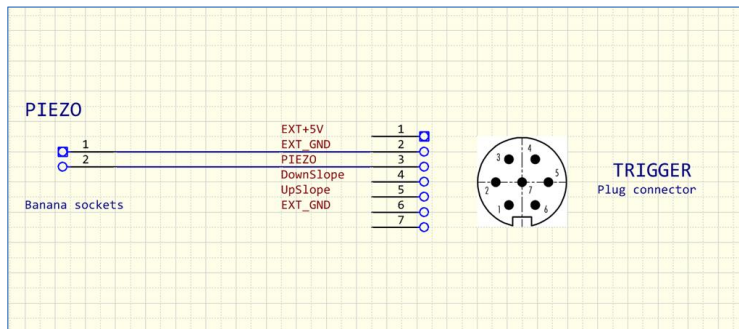

Example connection for a piezo trigger

9.1.5 GEOPHONE

Input impedance is 1.2 kΩ

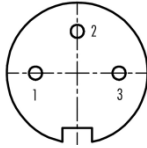

Female connector 3 contacts for single channel version

Contact	Geophone
Pin 1	G+
Pin 3	G-

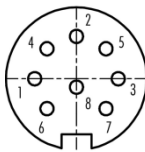

Female connector 8 contacts for 4-channel version

Contact	Geophone
Pin 1	G1+
Pin 2	G1-
Pin 3	G2+
Pin 4	G2-
Pin 5	G3+
Pin 6	G3-
Pin 7	G4+
Pin 8	G4-

Attenuator for sweep recording

Depending on the output voltage of different vibrators, the reference signal has to be attenuated to the geophone input level of 600 mV. The example circuitry will work from 5 V to 15 V signals.

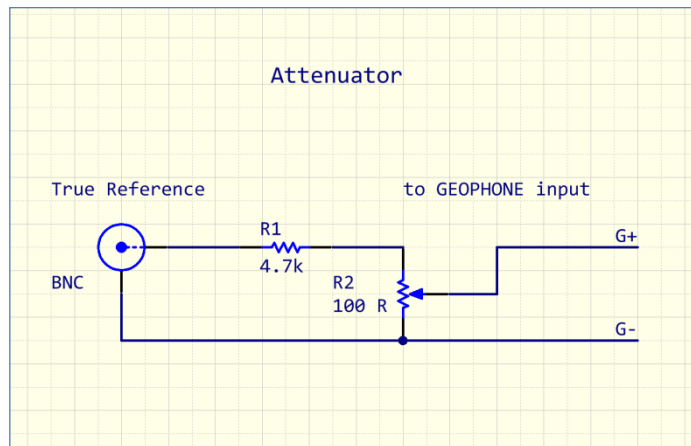

Example attenuator for 15 V signals